

TUTORIAL

Spatial Disorientation and Optical Illusions – Threat and Challenge

DESDEMONA

The most modern simulator motion platform

Michael Mayrhofer

Dr.-Ing. DI MBA

AMST®

AMST - SYSTEMTECHNIK GMBH

EUROPEAN FLIGHT TEST SAFETY WORKSHOP

November 10th-12th 2009

SAS Radisson, Vienna, Austria

Headquater



visit us at <http://www.amst.co.at>



AMST - aeromedical solutions around the world



Company Profile

ENGINEERING	25
SOFTWARE & FLIGHT SIMULATION	18
PROD. & SERVICES	40
FINANCE & ADMIN.	11
MARKETING & SALES	4

98

ACADEMICS	30%
GRADUATES	20%
UNDERGRADUATES	50%

100%

AMST



Products

- Dynamic Flight Simulator (Human Training Centrifuge)
- Hypobaric Chambers (High Altitude Chambers)
- Spatial Disorientation Trainer
- DESDEMONA – world novelty simulator motion platform
- Ejection seat trainer
- Night vision trainer
- FNPT II-MCC
- Flight Training Device

aeromedical solutions for the 21st century

AMST
AMST-SYSTEMTECHNIK GMBH



**FTD
PC-7 FLIGHT
SIMULATOR**



A-5282 RANSHOFEN / AUSTRIA e-mail: sales@amst.co.at www.amst.co.at

Main Centrifuge Projects

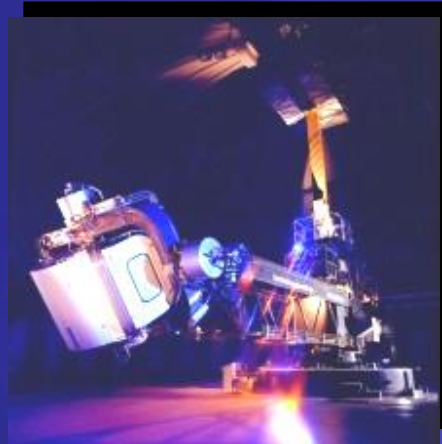

Human Training Centrifuge (HZF)
Königsbrück / Dresden

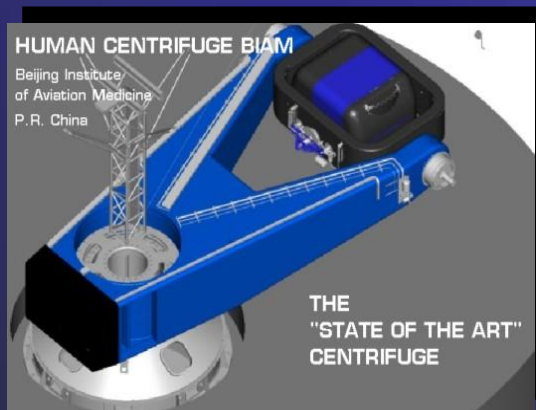

Human Centrifuge
Beijing / P.R.China



Human Centrifuge
LII Gromov

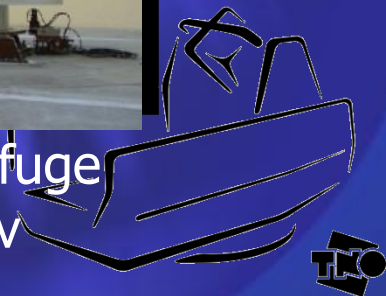

Centrifuge Video Clip

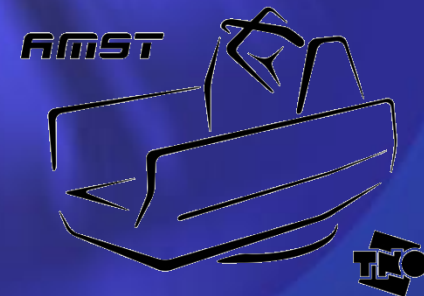
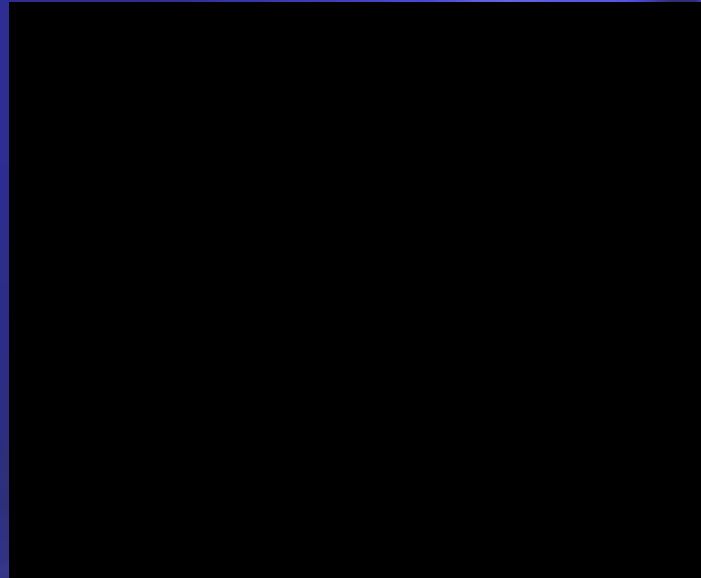

AVIATION – HUMAN FACTOR



Vision

Altitude /
Temperature

Accelerations /
Forces / Rotations

Noise / Vibrations



THE PRINCIPLE OF SPATIAL ORIENTATION

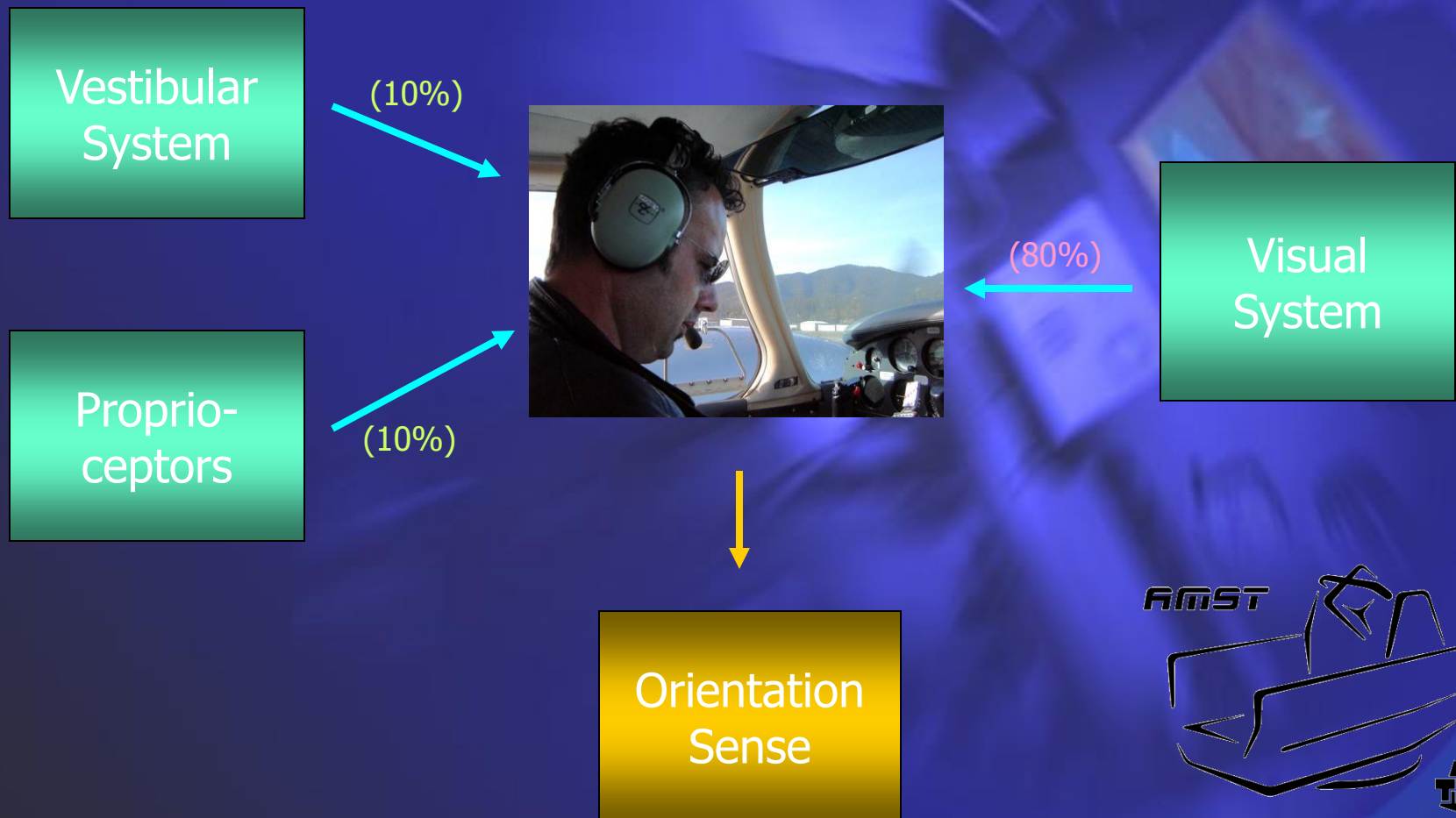

AIRFOX® DISO



SPATIAL
DISORIENTATION
TRAINING



AIRFOX® DISO Video Clip

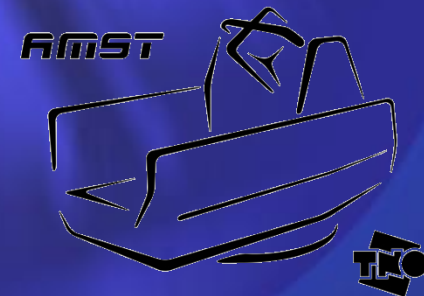
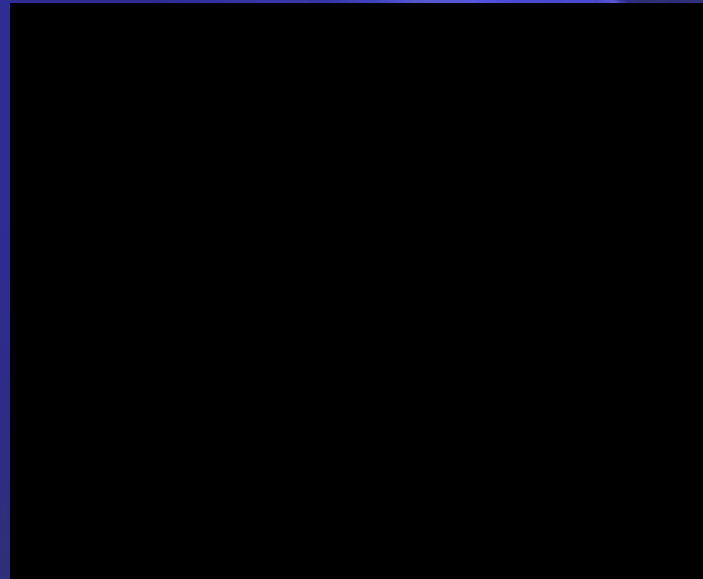

DESDEMONA

6-DoF

The most modern simulator motion platform

**Recognised with the
Federal Award for
Superior Innovation**

Motion Based Simulation

Hexapod



- 6 degrees of freedom
- no sustained g-forces
- limited yaw

Human Centrifuge



- 3 degrees of freedom
- sustained g-forces
- unlimited yaw



THE Future of Motion Based Simulation



„ALLDOER“ possible??

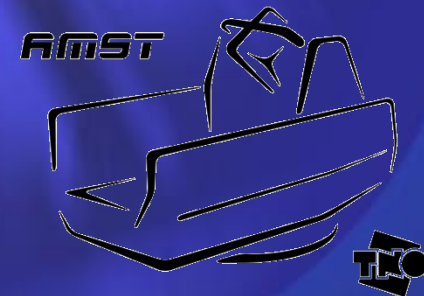

THE Answer

Innovative Motion Platform

DESDEMONA

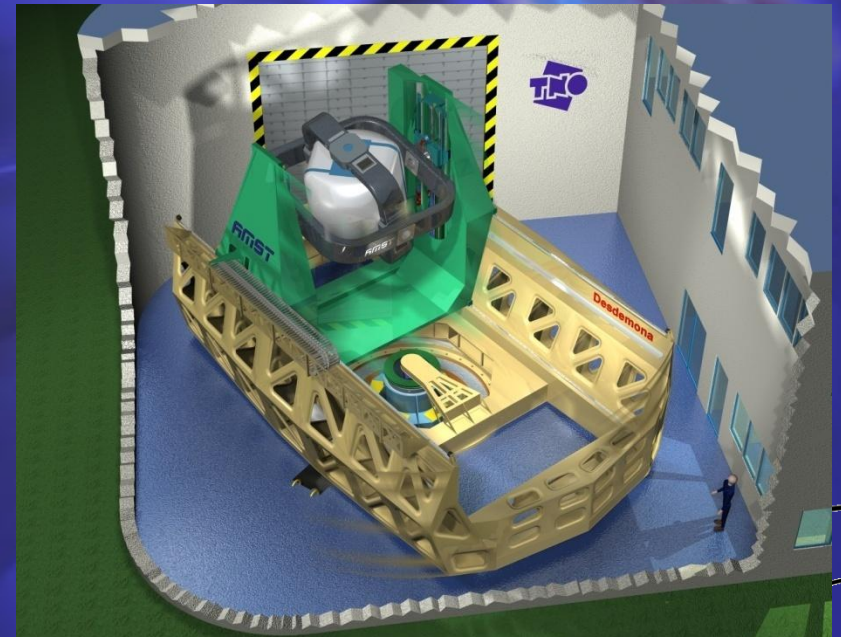

Concept

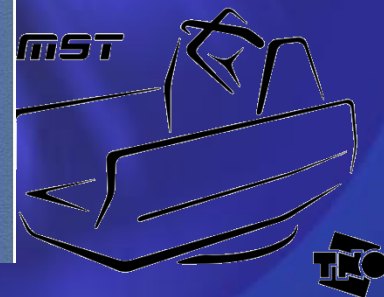
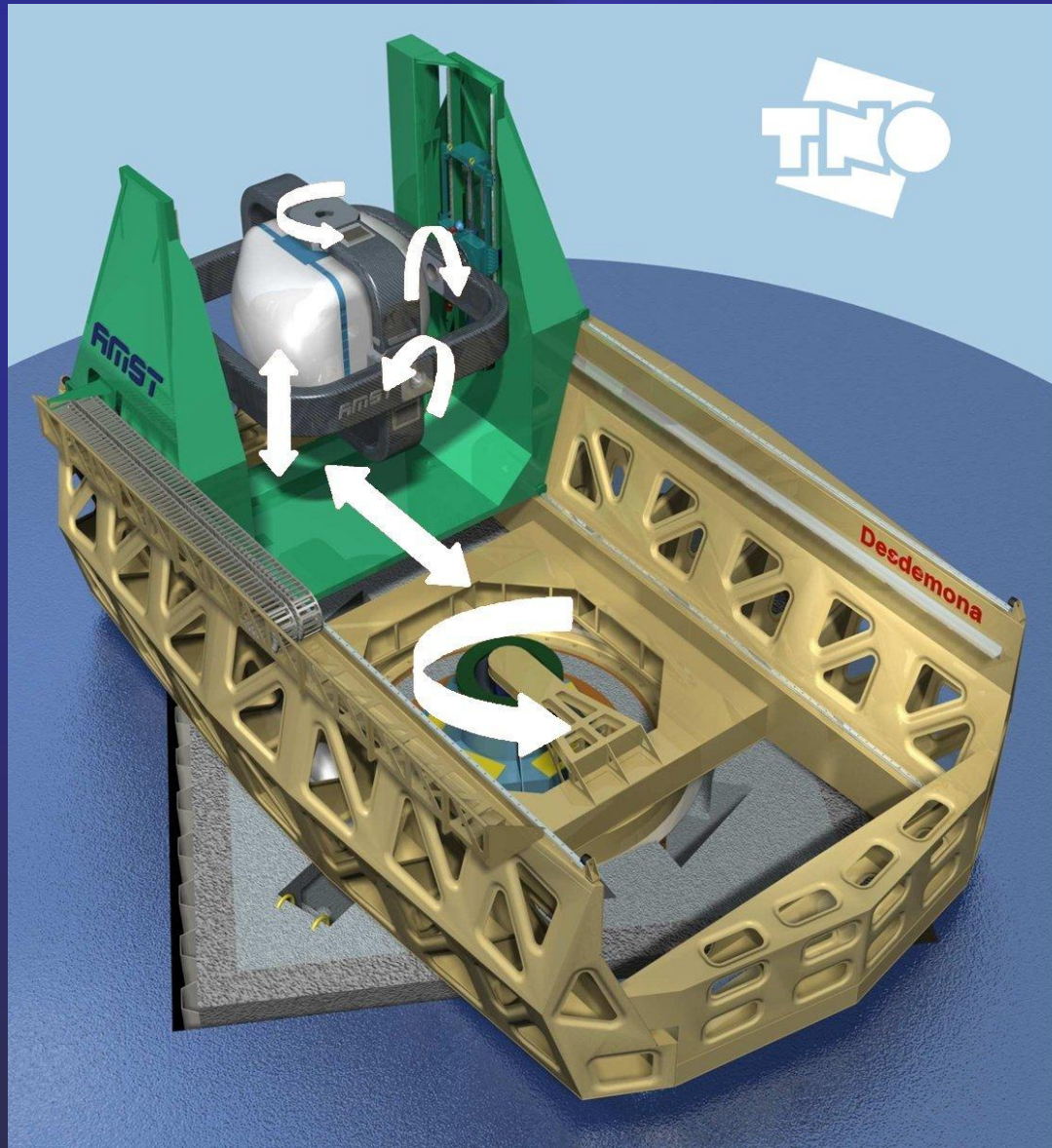

PRODUCT PLACEMENT

Innovative Motion Platform

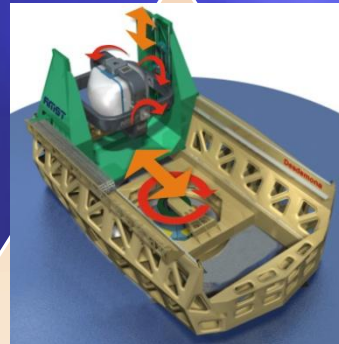

DESDEMONA

FLIGHT-
SIMULATORS

HIGH
PERFORMANCE
CENTRIFUGE

DISORIENTATION
& MOTION FILTERS



DESDEMONA

Motion Spec

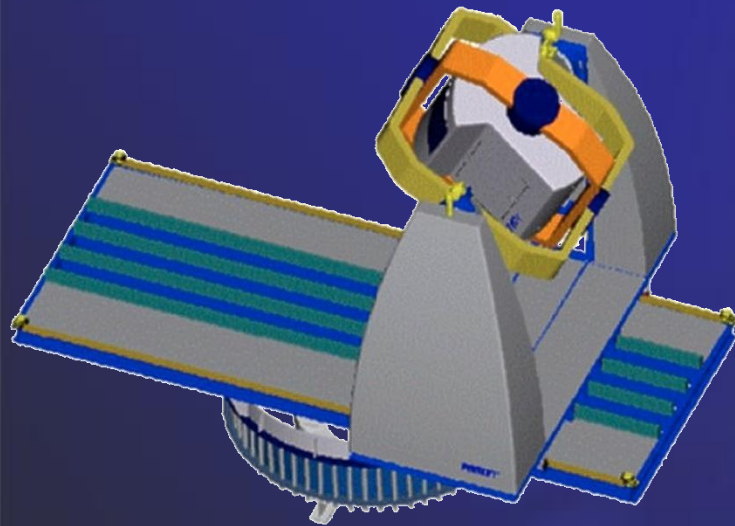

Acc. of main arm $\leq 45 \text{ }^\circ/\text{s}^2$

Horizontal motion 8 m

acc. $\pm 0.5 \text{ g}$

max. g-load 3 g

Vertical motion 2 m

acc. $\pm 0.5 \text{ g}$

Gimbal system

position

vel.

acc.

AMST $> 360^\circ$
 $\leq 180 \text{ }^\circ/\text{s}$
 $\leq 90 \text{ }^\circ/\text{s}^2$

DESDEMONA

Where are the degrees of freedom?

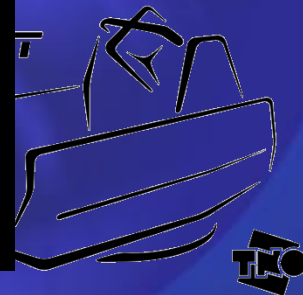
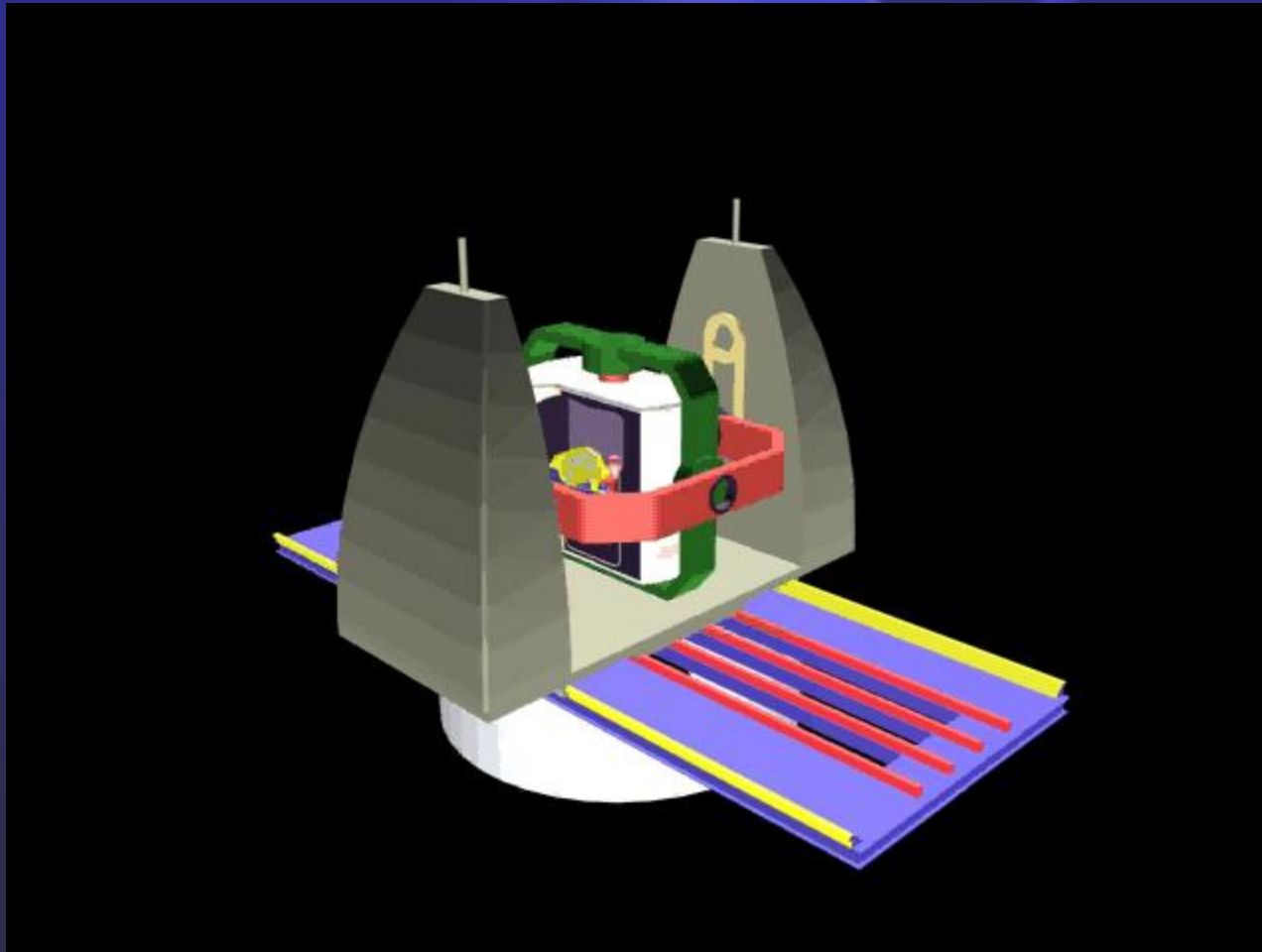

DESDEMONA

Working in Hexapod Mode

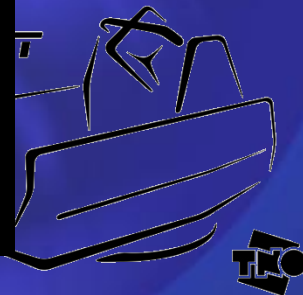
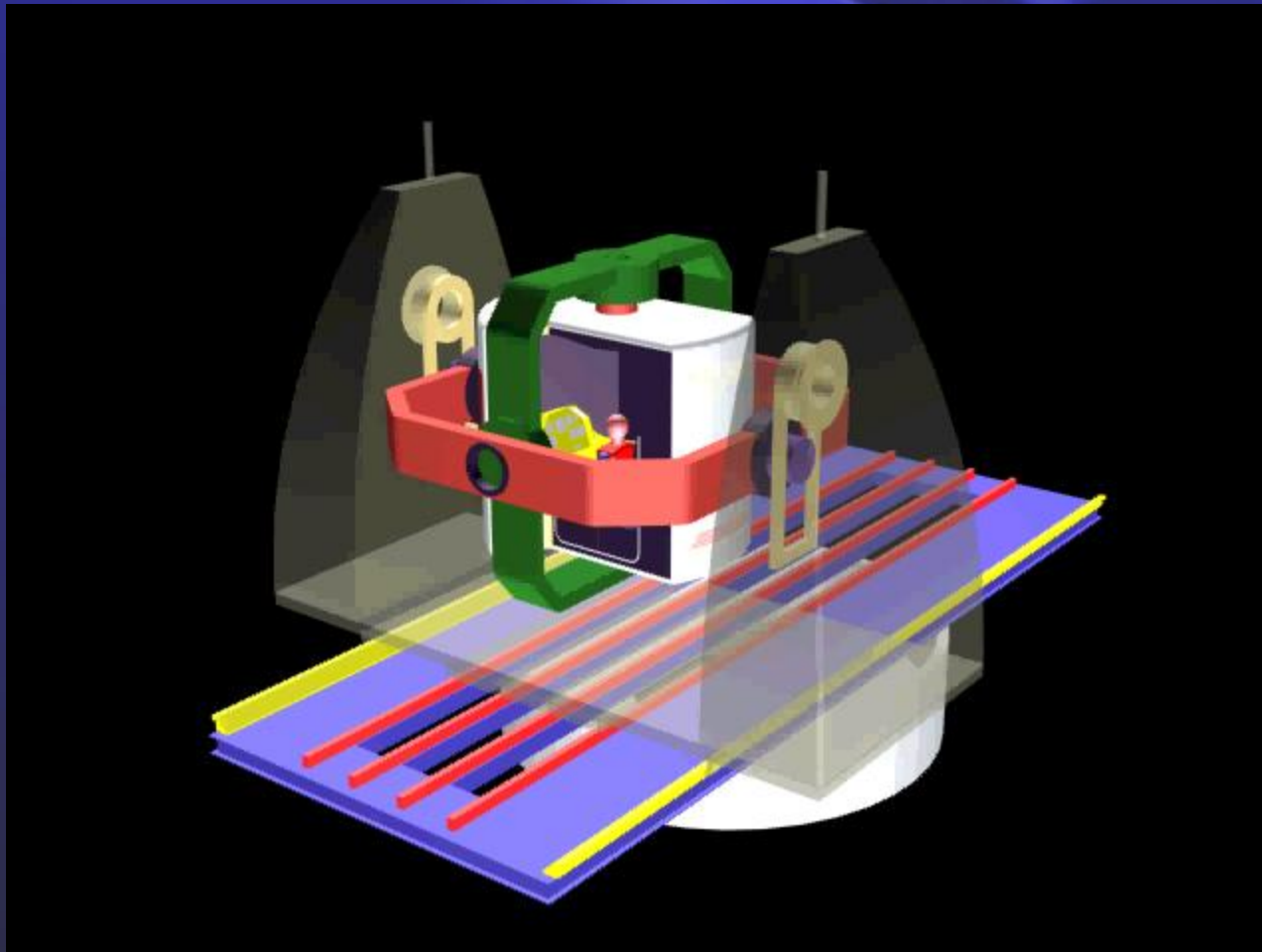

DESDEMONA

Working in Centrifuge Mode

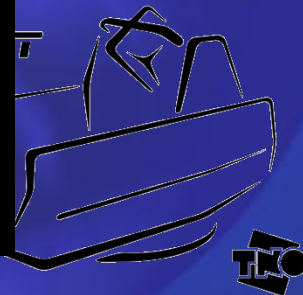
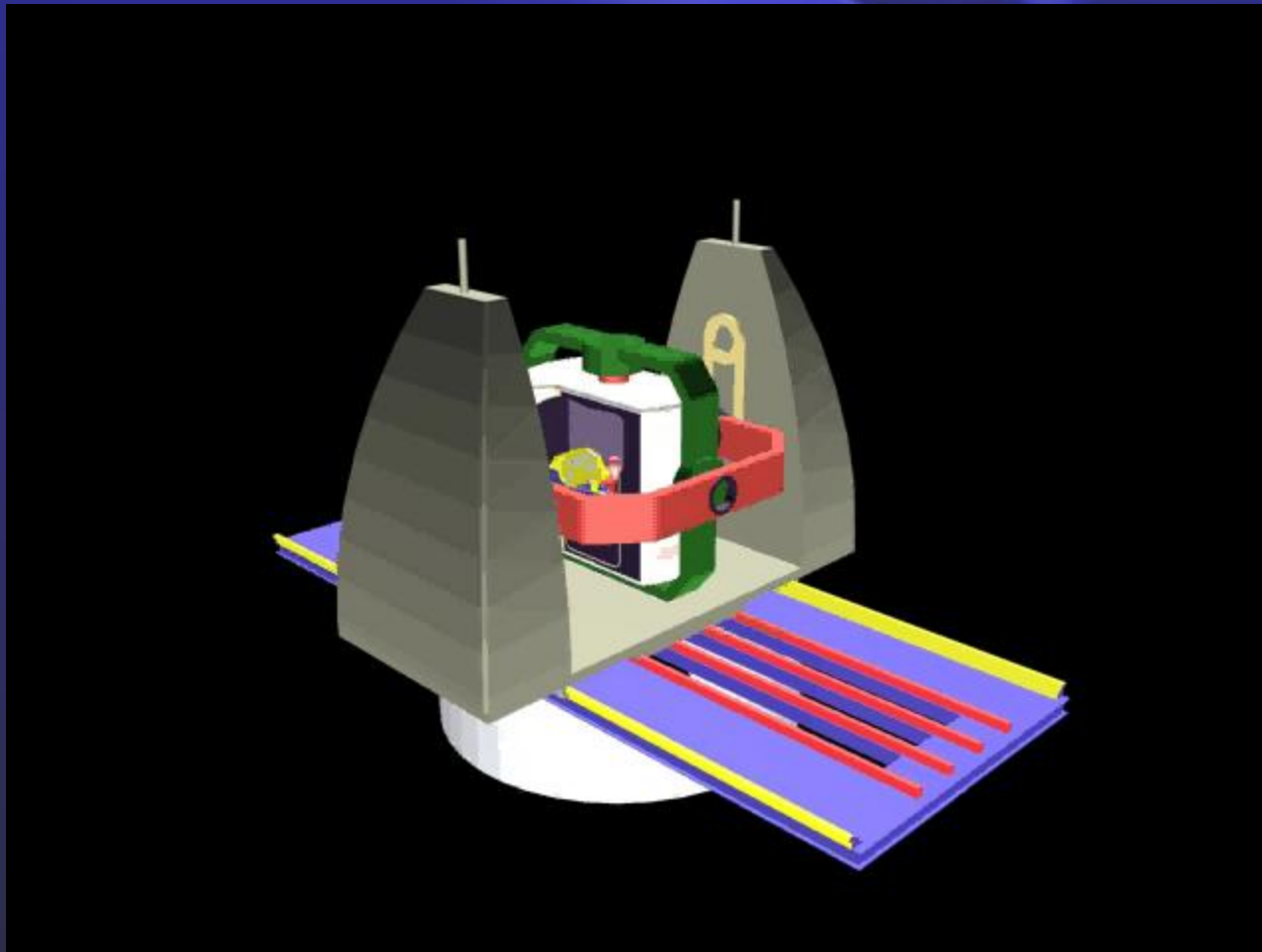

DESDEMONA

Combination of Modes?

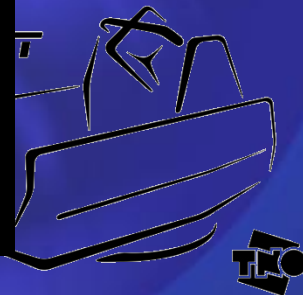
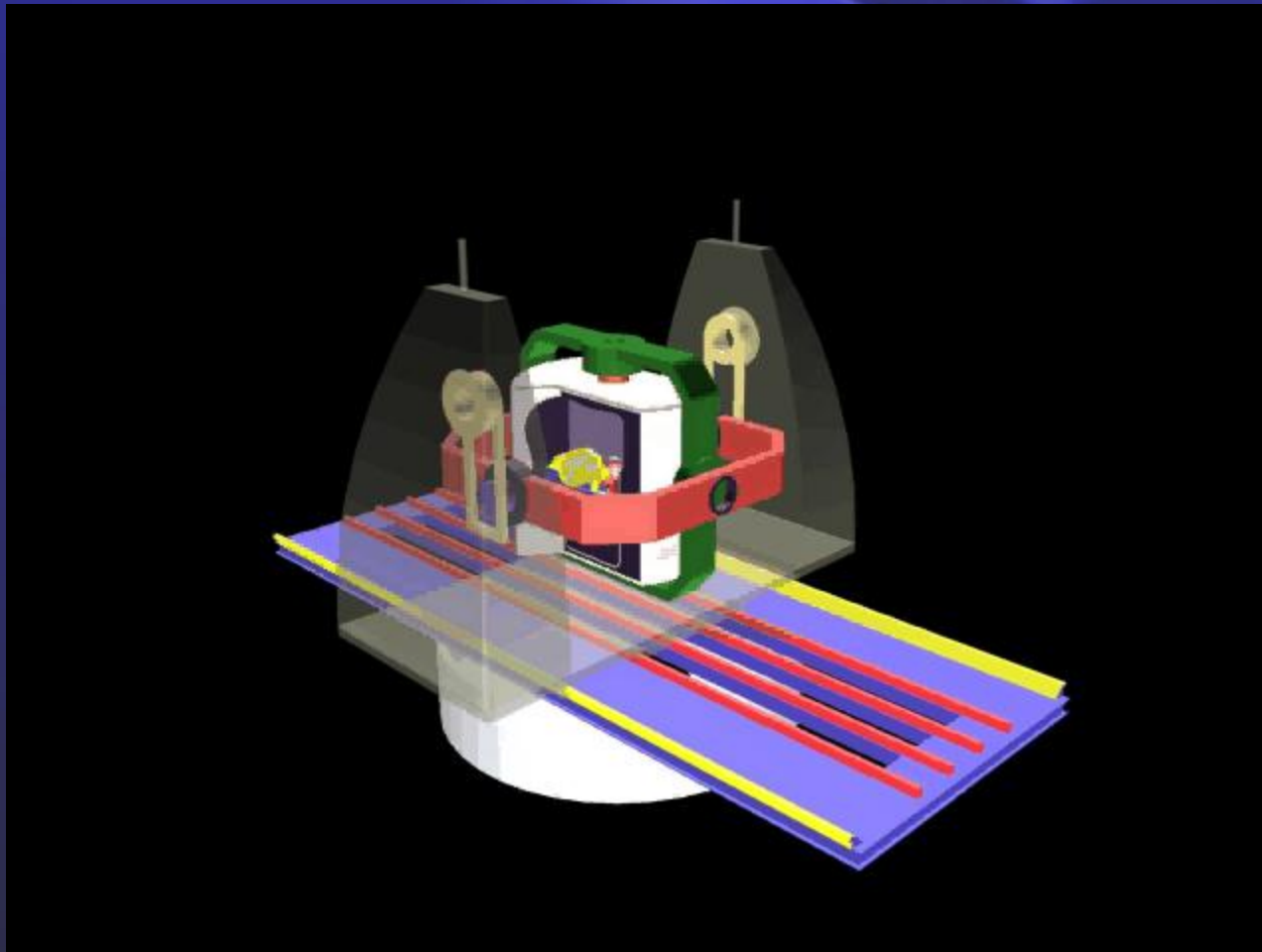

DESDEMONA

6-DoF

CE DECLARATION OF CONFORMITY
NR 1 0078 14

PRODUCT DESCRIPTION

Product name : DESDEMONA
Serial Number : 206631

MANUFACTURER

Company : AMST Systemtechnik GmbH
Address : P.O.Box 3
Place : Raasdorf
Zipcode : 63262
Country : Austria
Representative : Mr. Mark Seib Brown
Position : Quality Manager

INVESTIGATED BY

Company : Consultants Europe bv
Address : Nieuwstraat 80
Zipcode and place : 1311 BD Nieuwgeest
Country : The Netherlands

HARMONISATION

This product complies with the Safety regulations of the

 Machine Directive 98/37/EC
 Low Voltage Equipment 73/23/EEC
 Personal Equipment Directive 97/23/EC
 Electromagnetic Compatibility 89/338/EEC

and amongst others the following harmonised standards:

EN-EN 1000-1 EN-EN 202-1 EN-EN 202-2
 EN-EN 61000-6-3 EN-EN 61000-6-2 EN-EN 61000-6-4
 EN-EN-IEC 6110 EN-EN 60337-1 EN-EN 61010
 EN-EN 60204-1 EN-EN 12100 EN-EN 60439
 EN-EN-IEC 62040 EN-EN-IEC 60947
 EN-EN-IEC 60177 EN-EN 79-1

Pilsy Raasdorfen  Date: 15.01.2008
 Signature Manufacturer:  

The findings in this report refer only to the evaluated machine.

DESDEMONA Equipment

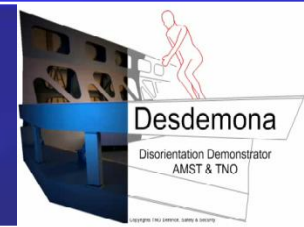

Cockpitvariants (interchangeable)

- Aircraft
- Vehicle
(ground based)
- Ship
(surface & underwater)
- Space Vehicle

3-Chanal Visual

Soundeffects

Medical Data Transmission

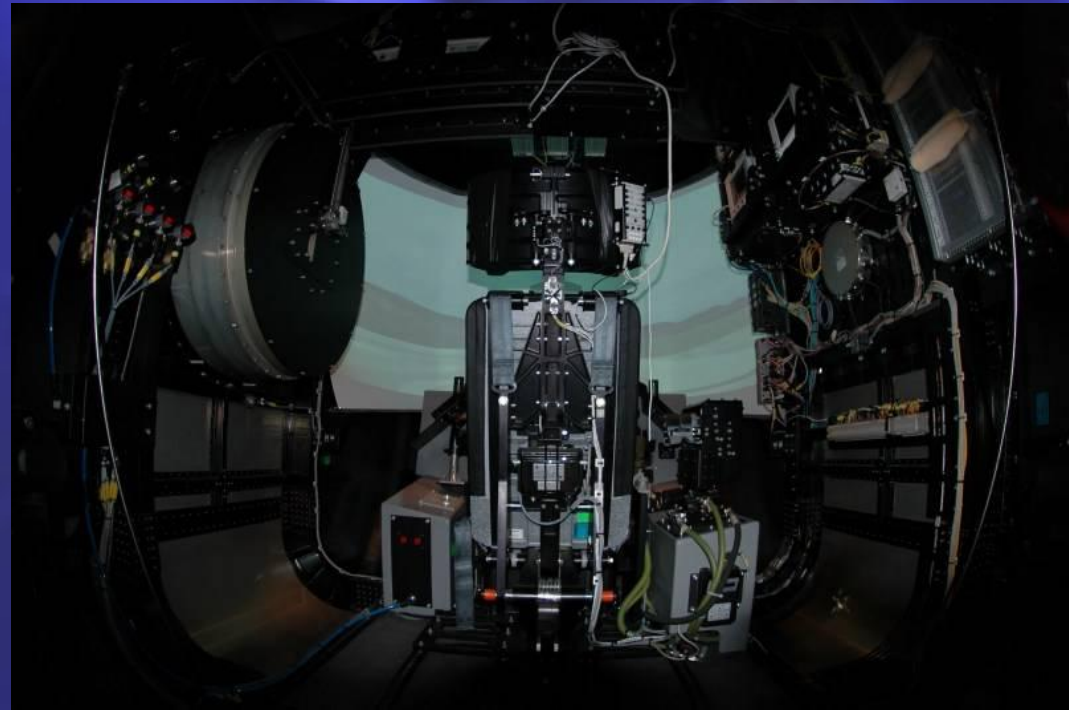

DESDEMONA Status

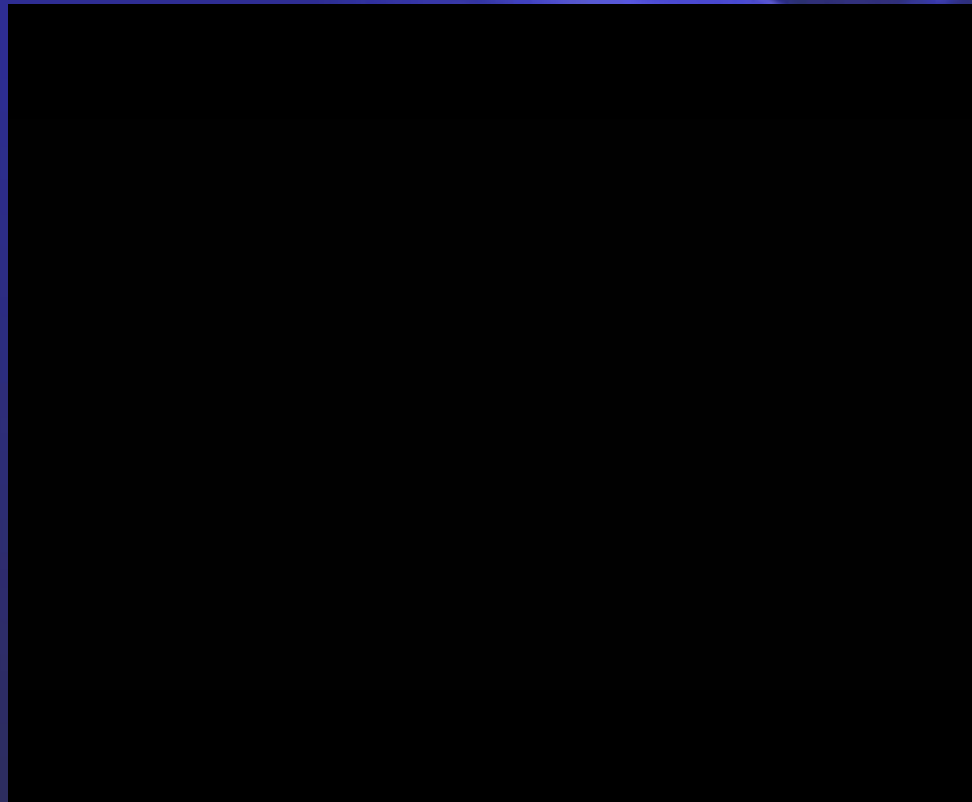
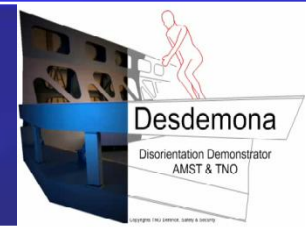

www.desdemona.eu

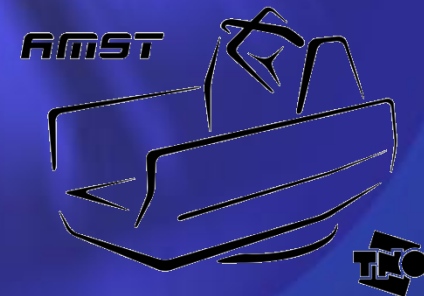

DESDEMONA Development

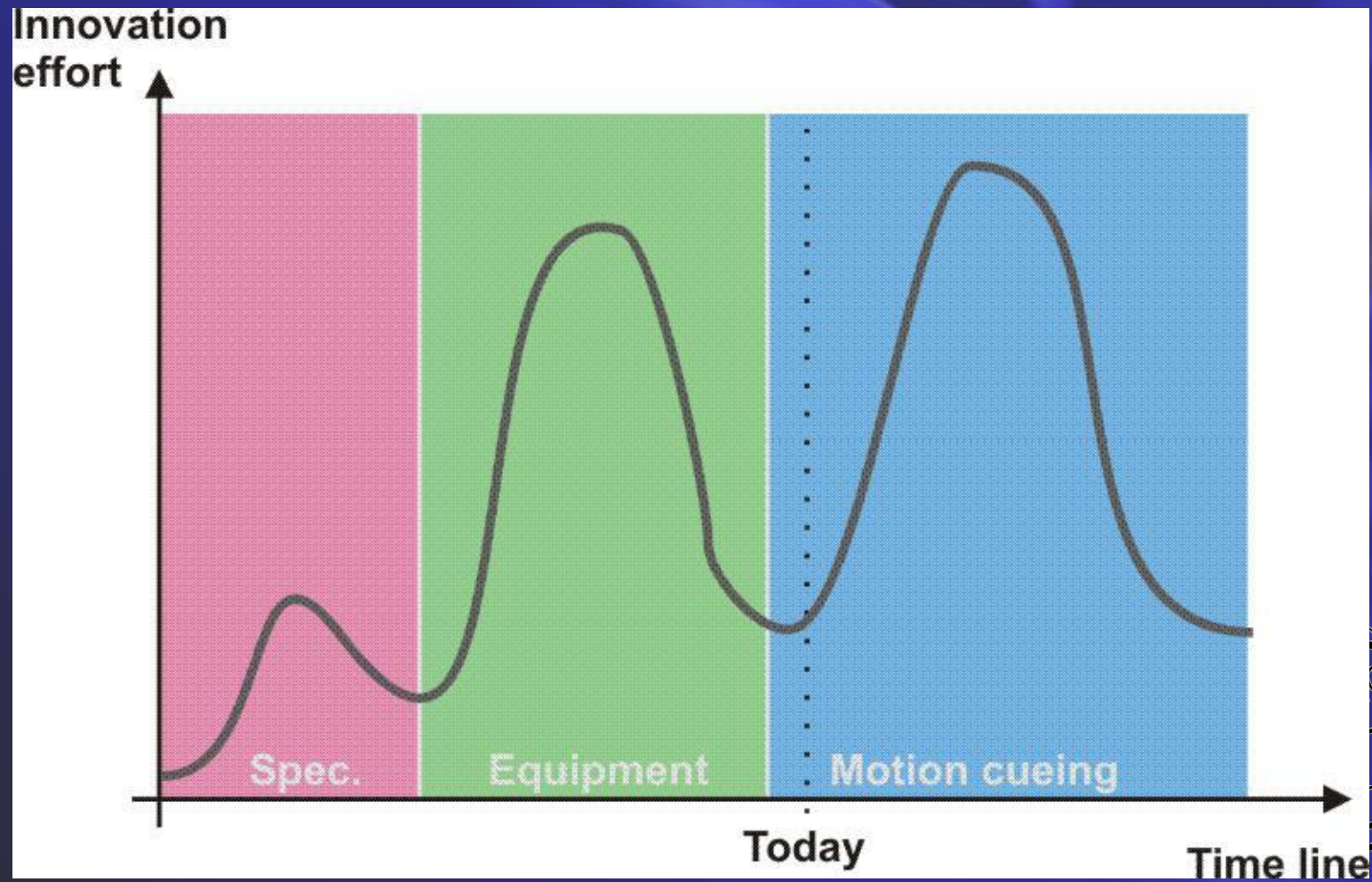
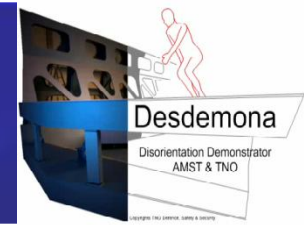

DESDEMONA Development

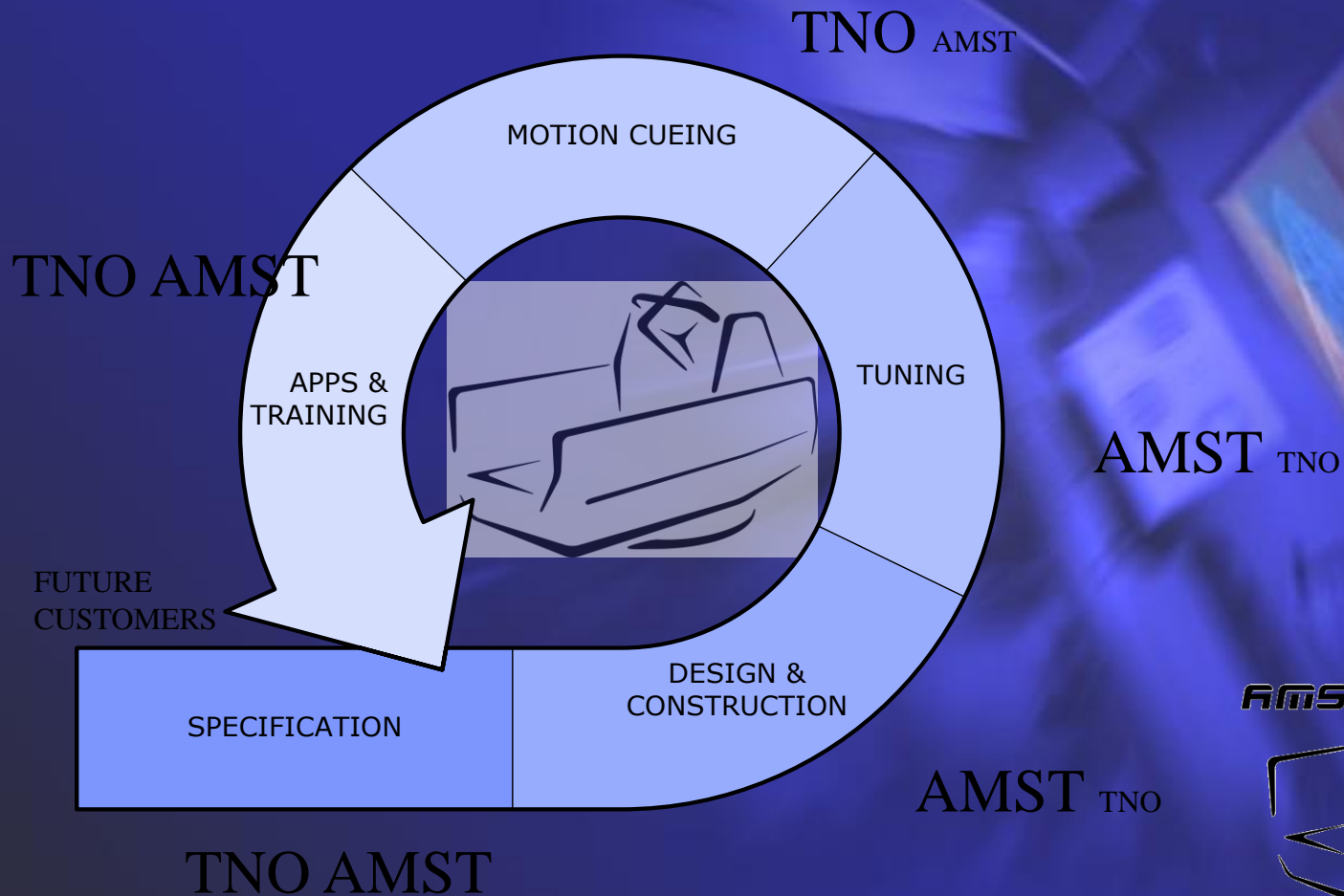
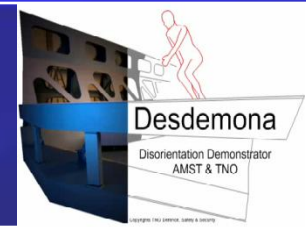

DESDEMONA Motion Cueing

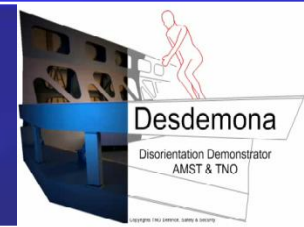

Washout filter design

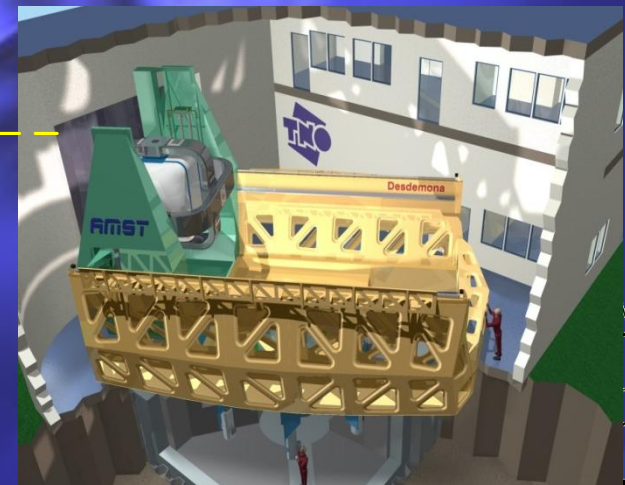
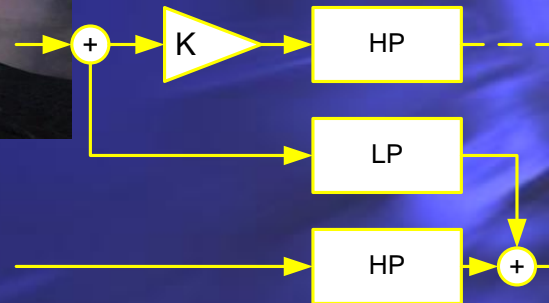

DESDEMONA Advanced Motion Cueing

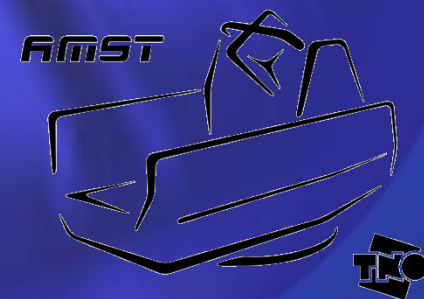
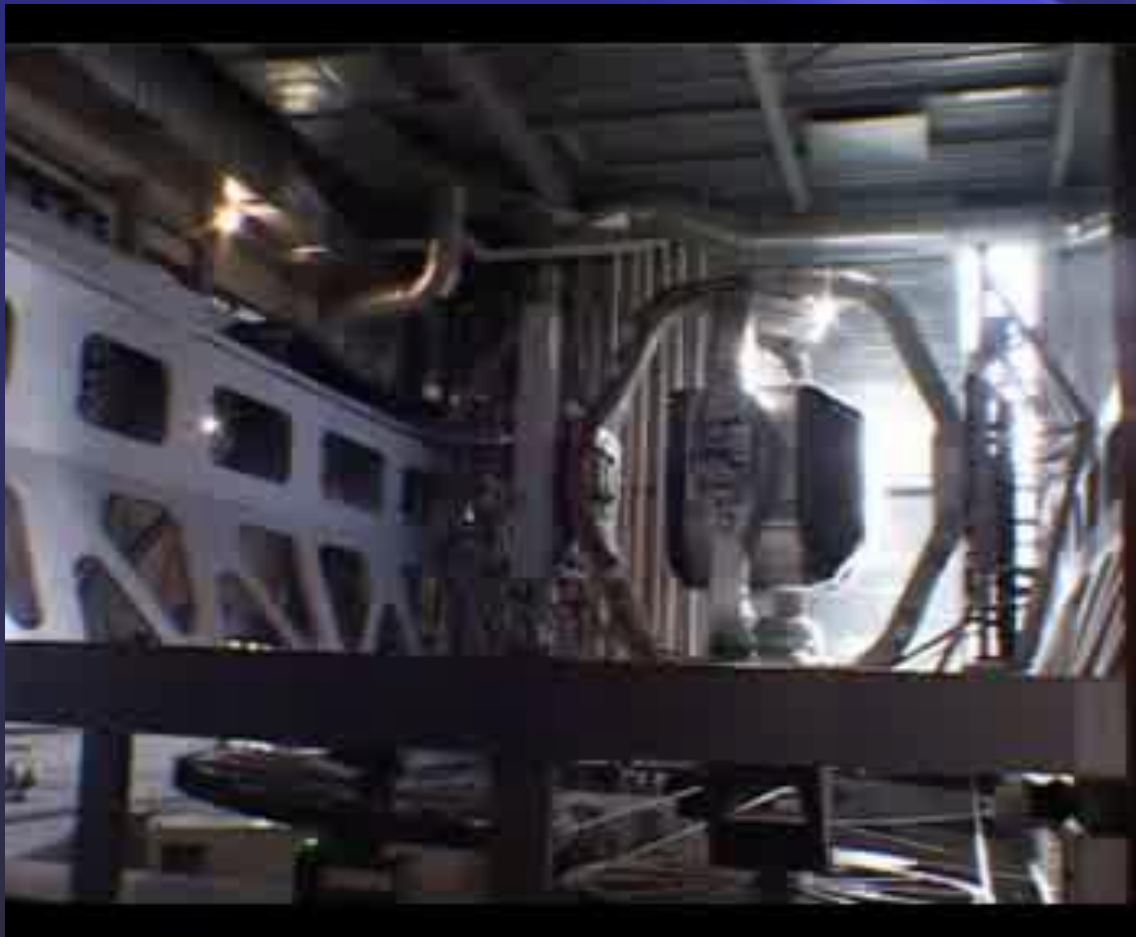
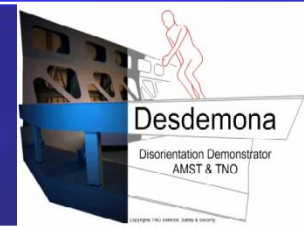

DESDEMONA G-Cueing

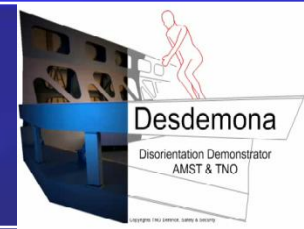

DESDEMONA

Car Driving Motion Cueing

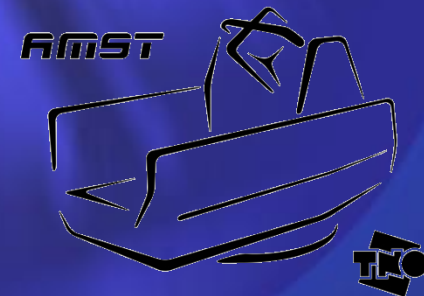
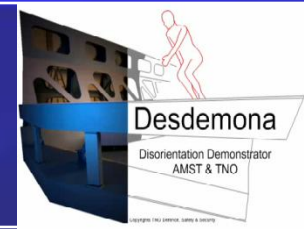

DESDEMONA

Ship Motion Cueing

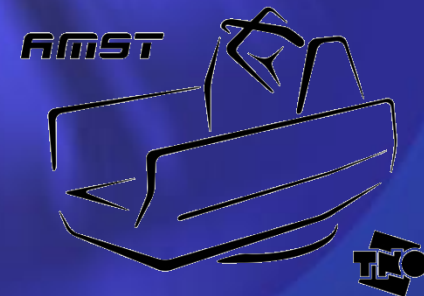
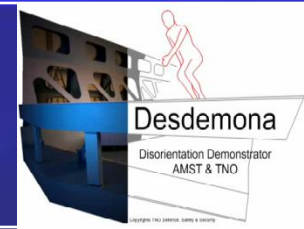

DESDEMONA F-16 Motion Cueing

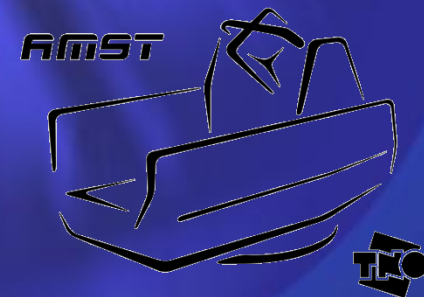
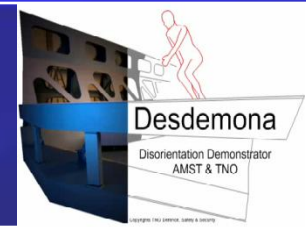

DESDEMONA S U P R A

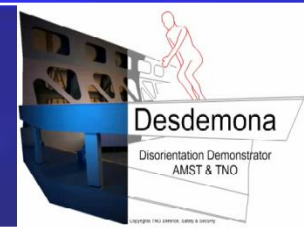

Simulation of Upset Recovery in Aviation

- Unusual attitude of civil aviator (fly-by-wire/conventional 100 seater)
43 % of all accidents caused by upset conditions (recent 15 years)
- In/Out-of the normal flight envelope
- Modern motion platform
- Develop training for different scenarios with experts (scientists, aircraft manufacturer, pilots)
- Provide a standard training for up-initio and reccurent training
- Rating of training by international peer group
- Adapt training
- Standardize training for pilot's professional education.
(regulations)

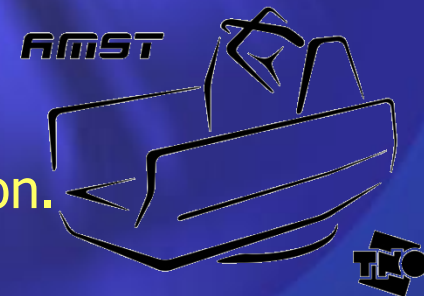



AMST

www.amst.co.at

AMST - SYSTEMTECHNIK GES.M.B.H.
P.O.BOX 3
5282 RANSHOFEN
AUSTRIA

PHONE: ++43 7722 892-0
FAX: ++43 7722 892-99
E-MAIL: office@amst.co.at

Roller Coaster Simulation

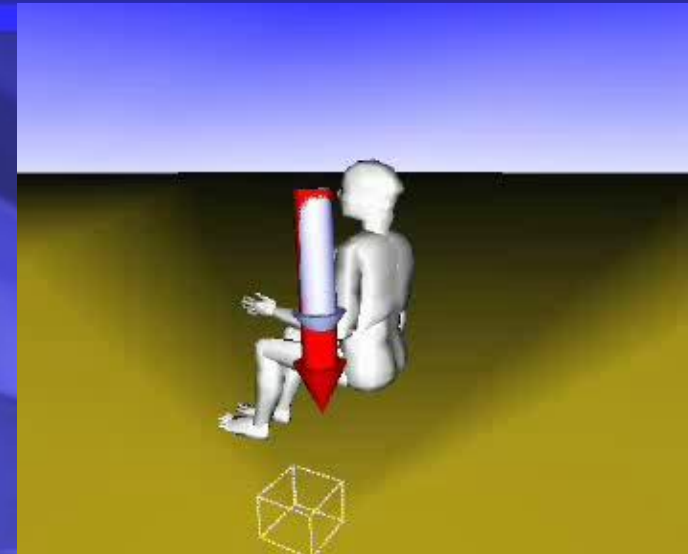

Catapult Launch Simulation



F18 Catapult launch:
4G in 1 sec.

